

Intelligent Lift Control Valve with Electronic Card

$Q_{\max} = 500 \text{ l/min}$, $p_{\max} = 80 \text{ bar}$

Leak-free, two-stage, electronically controlled, without frequency control

Series iValve – i250 and i500

1 Information – lift-control valve



- No modifications of the travel curve or mechanical adjustments are necessary
- Constantly short travel times, regardless of loading and temperature
- Constant levelling accuracy of $\pm 3 \text{ mm}$, which prevents dangerous tripping accidents
- Self-monitoring function guarantees fully integrated A3 conformity (TÜV approved)
- Pleasant acceleration and slowdown thanks to an electronically controlled travel curve
- Soft-stop function for smooth approach and entry

1.1 Description

The iValve lift-control valve is an electronically controlled hydraulic valve block for controlling hydraulic lifts. The iValve is situated on the hydraulic power unit and activated by the lift control system. Electronic control is accomplished by an electronic unit – the iCon – that is housed in the control cabinet. At standstill, the weight of the lift is supported by a check valve integrated in the iValve. In operation, the electronic controller regulates the states “Travel UP” and “Travel DOWN”, and the transitions between these states. In the electronic unit, the travel is represented in a form known as

travel curves. During operation, the travel curves for that particular lift are optimised by the learning algorithm “iTeach”. In addition, the valve block includes the following functions and components: a hand pump with manual emergency lowering (with piston-creep prevention), a ball valve, a pressure gauge, a pressure sensor with up to two pressure switches, speed monitoring, a temperature sensor, an emergency stop DOWN valve (UCM/A3) in accordance with EN 81.

1.2 Technical data – iValve

General characteristics	Description, value, unit	
	i250	i500
Designation	Intelligent lift-control valve	
Design	Leak-free, two-stage, electronically controlled	
Mounting method	G 1 Pipe mounting or low mounting (see interface in “Installation info.”)	G 1½ Pipe mounting or low mounting (see interface in “Installation info.”)
Size	- Port P - Port T - Port HP - Port Z - Port Z1 G 1 G 1 Hose, oil-resistant (id = 8 mm, od = 12 mm) 28 L EN ISO 8434-1 G ¼	G 1½ G 1½ Hose, oil-resistant (id = 8 mm, od = 10 mm) 42 L EN ISO 8434-1 G ¼
Tightening torque	- Port P - Port T - Port HP - Port Z - Port Z1 230 Nm \pm 10 % 230 Nm \pm 10 % Hose 10 x 1 (pushed on) 230 Nm \pm 10 % 35 Nm \pm 10 %	500 Nm \pm 10 % 500 Nm \pm 10 % Hose 10 x 1 (pushed on) 500 Nm \pm 10 % 35 Nm \pm 10 %

General characteristics	Description, value, unit	
	i250	i500
Weight	10.4 kg	22.5 kg
Mounting attitude	As illustrated – see section “Dimensions”	
Ambient temperature range	+2 °C ... +40 °C	

Hydraulic characteristics	Description, value, unit	
	i250	i500
Nominal pressure	80 bar	80 bar
Maximum flow rate	250 l/min	500 l/min
Nominal flow rate Down (Z > T)	see section “Performance graphs”	
Flow direction	P → T (bypass) P → Z (UP) Z → T (DOWN)	
Hydraulic fluid	HL and HLP mineral oil to DIN 51 524; for other fluids, please contact BUCHER	
Hydraulic fluid temperature range	+0 °C ... +60 °C	
Viscosity range	20 ... 500 mm ² /s (cSt)	
Minimum fluid cleanliness Cleanliness class to ISO 4406 : 1999	Class 21/19/16	

Electrical characteristics	Description, value, unit	
	i250	i500
Supply voltage	24 VDC	
Supply voltage tolerance	± 10 %	

1.3 Schematic – iValve

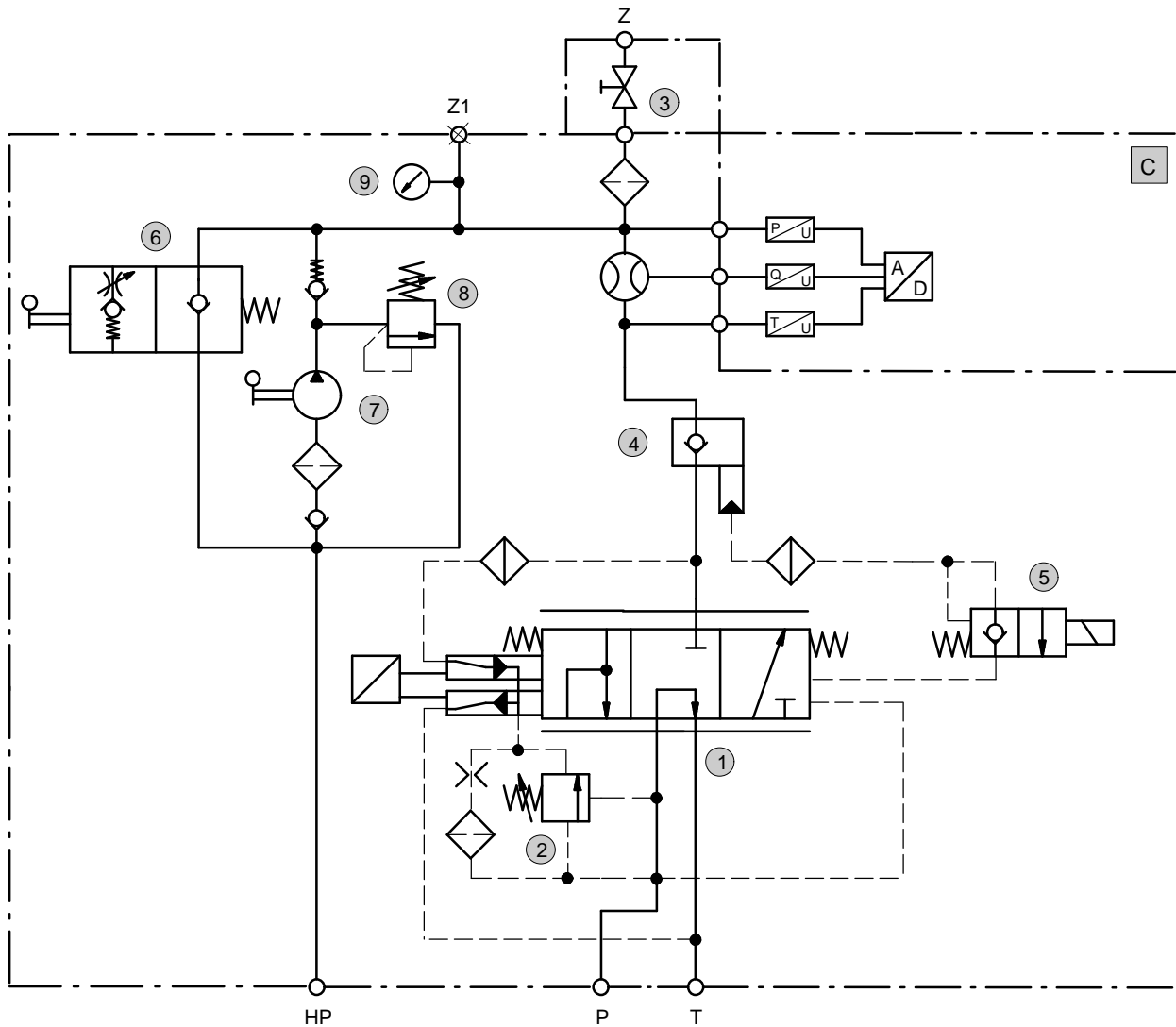

300-P-10024709

Item	Description
1	Main spool
2	Pressure relief valve
3	Ball valve
4	Pilot operated check valve
5	Emergency stop DOWN valve (UCM / A3)
6	Piston-creep prevention
7	Hand pump
8	Pressure relief valve in the hand pump
9	Pressure gauge

Item	Description
	iCon (included in the delivery)
C	iBox
P	Pump
T	Tank
HP	Hand pump
Z	Cylinder
Z1	Test port

1.4 Performance graphs

Legend

---	500 mm ² /s (cSt) Motorex Corex HLP 46 at approx. 2 °C
—	75 mm ² /s (cSt) Motorex Corex HLP 46 at approx. 30 °C

1.4.1 iValve 250

$\Delta p = f(Q)$ Pressure drop - Flow rate characteristic [i250/160]
(min. dynamic pressure/flow rate)

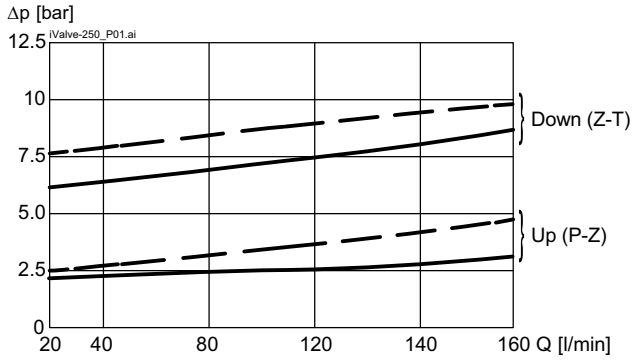

$\Delta p = f(Q)$ Pressure drop - Flow rate characteristic [i250/250]
(min. dynamic pressure/flow rate)

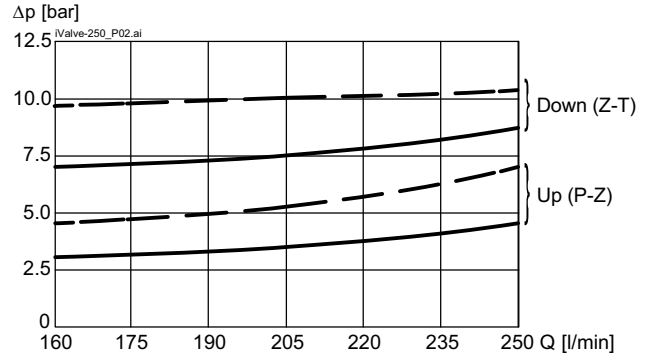

1.4.2 iValve 500

$\Delta p = f(Q)$ Pressure drop - Flow rate characteristic
(min. dynamic pressure/flow rate)

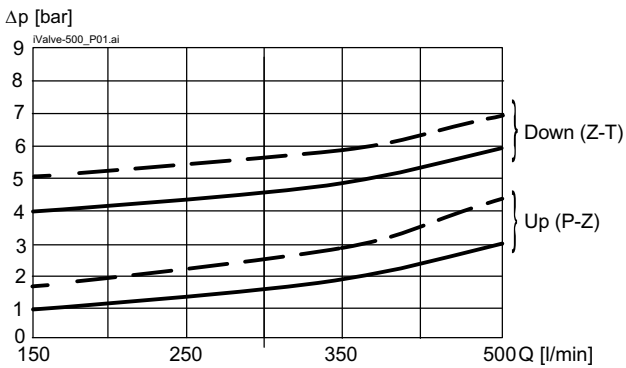

1.5 Dimensions, interface iValve – i250

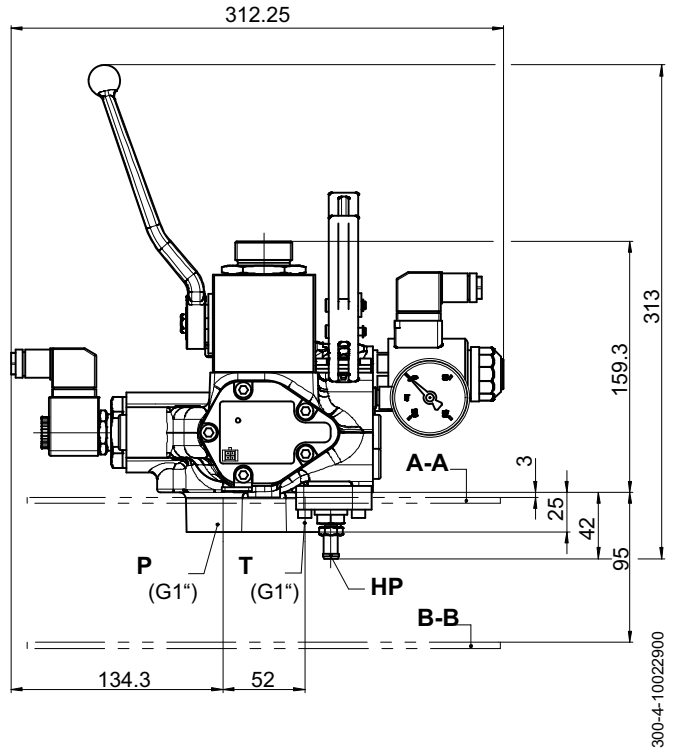
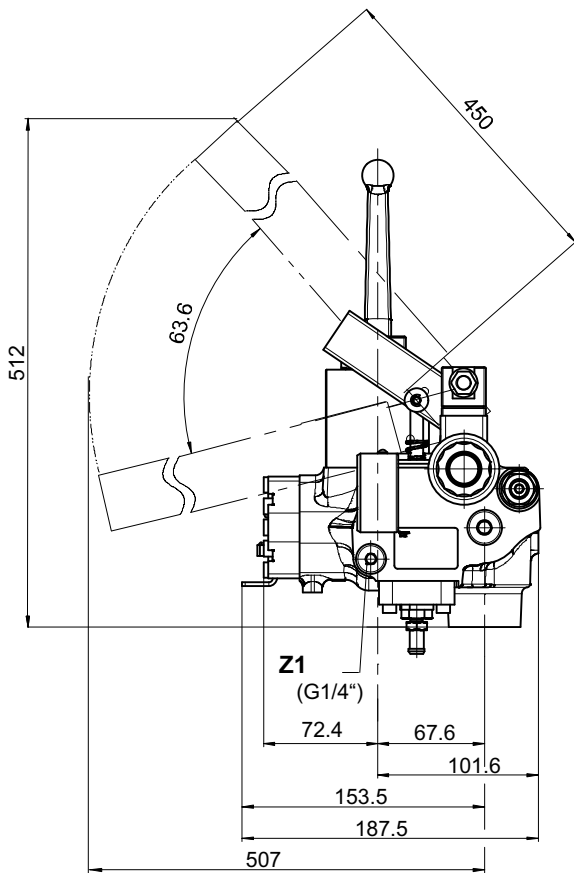

Low-mounting connection – see Figure A-A

Pipe-mounting connection – see Figure B-B

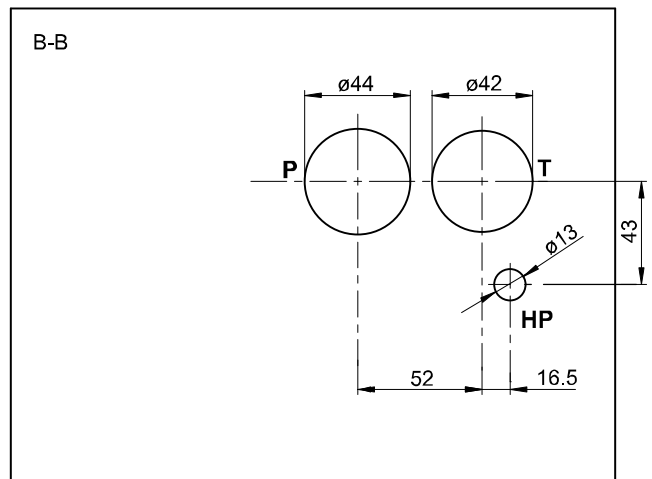
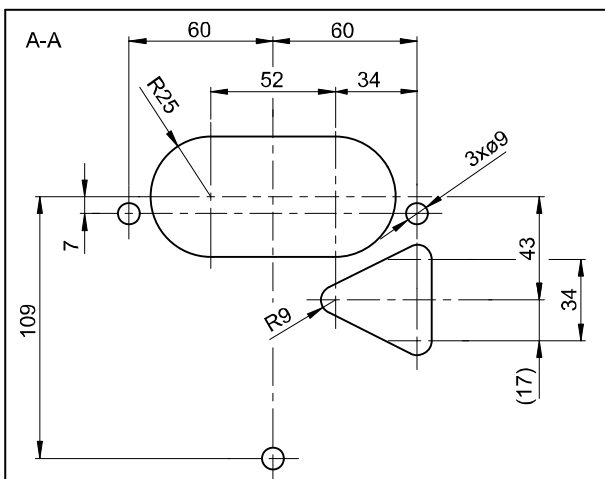

1.6 Dimensions, interface iValve – i500

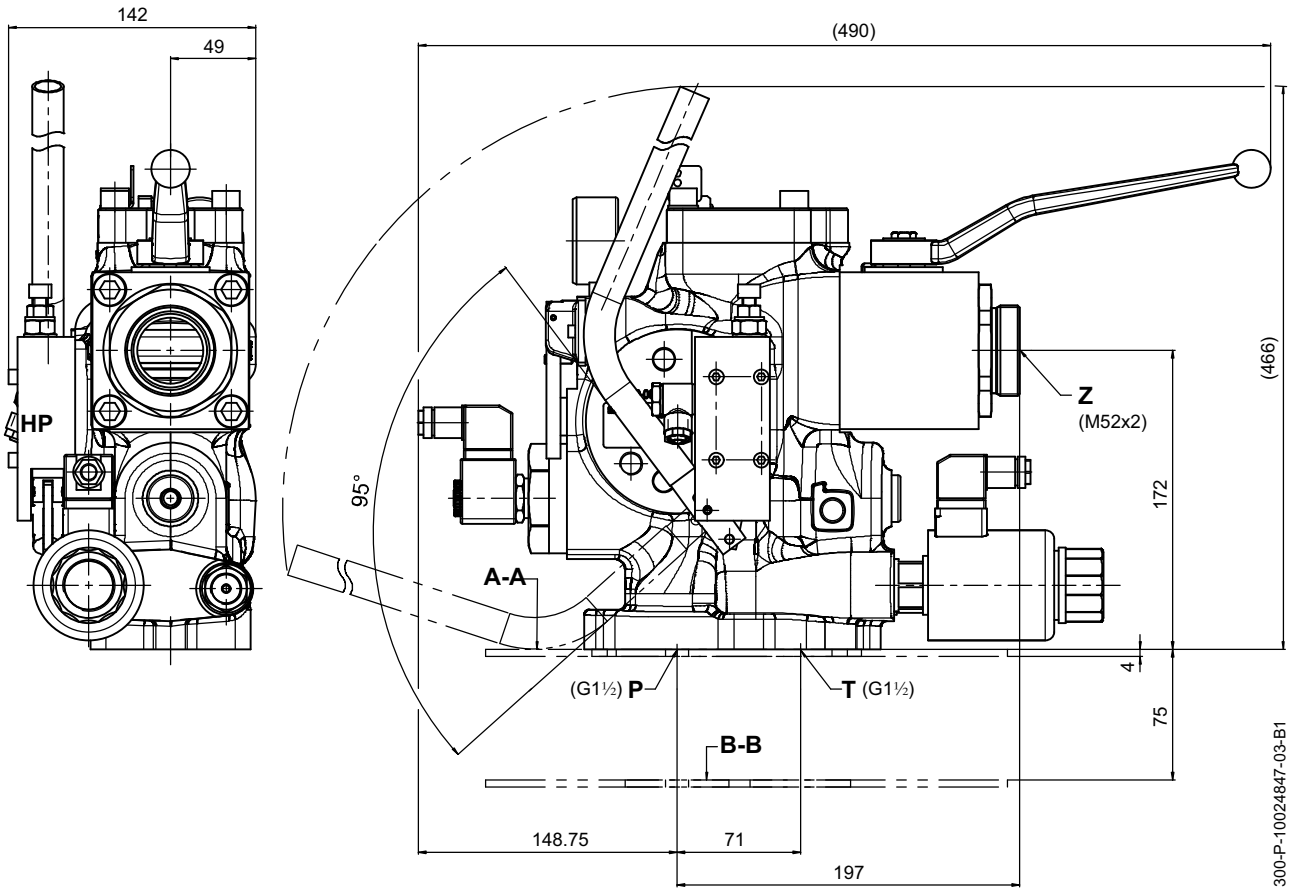

300-P-10024847-03-B1

Low-mounting connection – see Figure A-A

Pipe-mounting connection – see Figure B-B

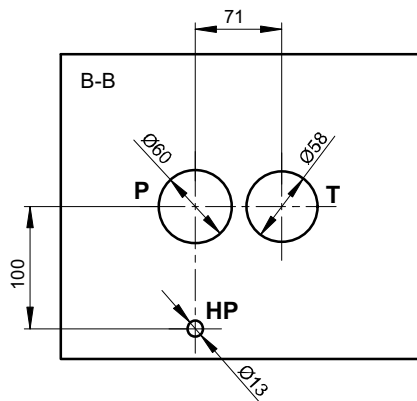
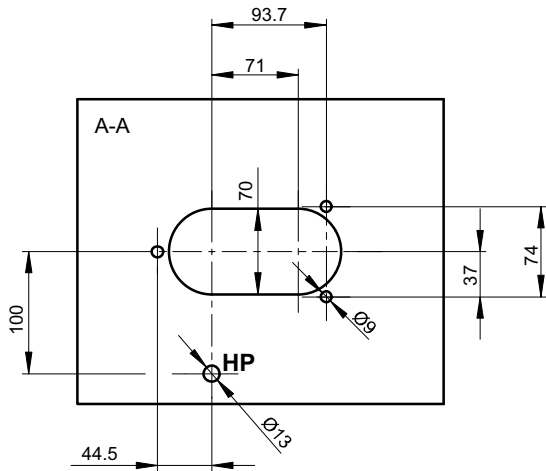

300-P-10024847-03-B2

1.7 Application examples

- The lift-control valve is an electronically controlled hydraulic valve block for controlling hydraulic-powered passenger and goods lifts.
- The lift-control valve is situated on a hydraulic power unit and activated by a lift control system.

1.8 Model code – iValve

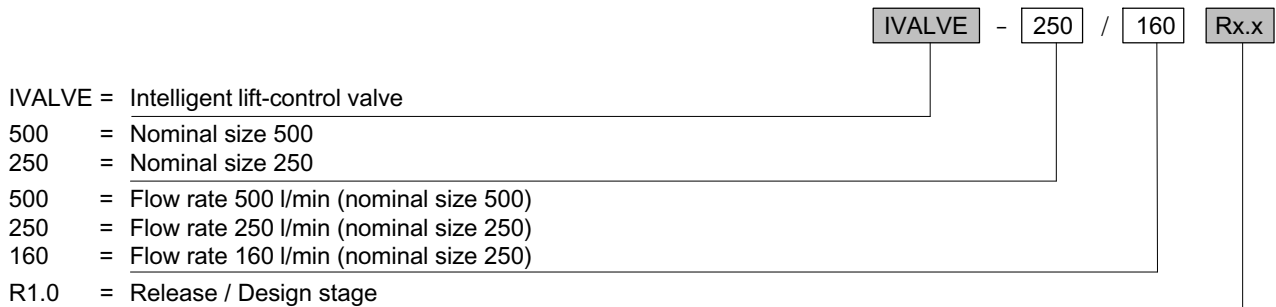

2 Electronic card for lift-control valve – iCon

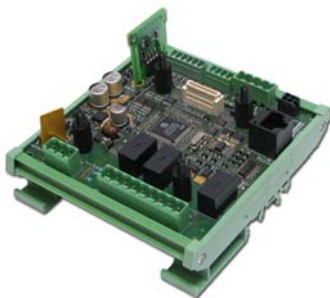

- Potential-free switching output for faults
- Two configurable switching outputs (pressure switch, train speed supervision)
- Functions can be expanded via options board

2.1 Description iCon

The iValve lift-control valve is an electronically controlled hydraulic valve block for controlling hydraulic lifts. The electronic control is accomplished by an electronic unit – the iCon – that is housed in the control cabinet. In operation, the electronic controller regulates the states “Travel UP” and “Travel DOWN”, and the transitions between these states. In the electronic unit, this travel is represented in a form known as travel curves. During operation, the travel curves for that particular lift are optimised by the learning algorithm “iTeach”.

The ParamCard is a memory card on which the system-specific parameters and data are stored. The ParamCard plugs into the iCon. Without the ParamCard being plugged in, no lift travel can be carried out.

2.2 Technical data

General characteristics	Description, value, unit
Designation	iCon
Design	Printed circuit board with 4 layers
Electrical connection - solenoids - electronics	3-pin square plug to ISO 4400 / DIN 43650 PCB connector 3.5 / 5 mm (screw terminals) Plug connector kit available - see the chapter Accessories
Mounting method iCon	15/35 mm cap rail acc. to EN 50035 (G32) or EN 50022 (TS15, TS35)
Mounting method	Option boards 4 spacer studs M4x16 (included in delivery)
Weight	0.20 kg
Ambient temperature range	+2 °C ... +40 °C
Relative air humidity	0...90% (without condensation)
Dimensions (overall sizes W x H x D)	112 x 122 x 63 mm (without options board)
Supply voltage	24 VDC
Supply voltage tolerance	± 10 %
Max. ripple	250 mV _{pp max.} (ripple and noise)
Power consumption at max. control current	50 W (i250) – 120 W (i500)
Command inputs	GND active / +24 V active (configurable)
Switching outputs	Potential-free relay contacts
Relative duty cycle	100 %
Max. Nominal power consumption at standstill	3 W
Relay contact rating: Min. control current Max. voltage Max. power	10 mA / max. 3 A 250 VAC 750 VA (AC) / 90 W (DC)
Electromagnetic compatibility: interference immunity	EN 12016
Electromagnetic compatibility: interference emission	EN 12015
Protection class to ISO 20 653 / EN 60 529	IP 00

2.3 Block diagram

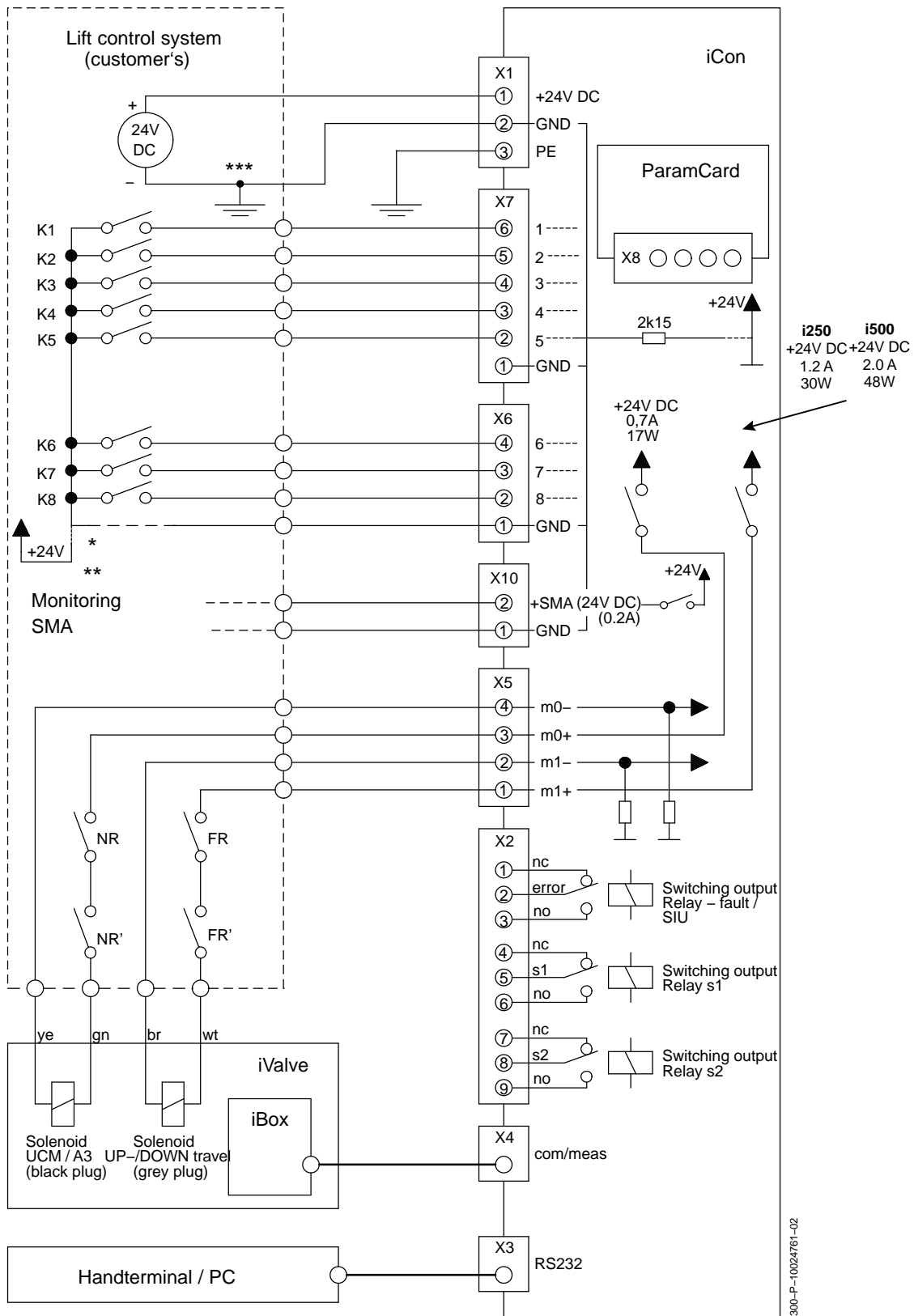

* Configurable via software, GND-active/ +24V-active (applies to all inputs K1 ... K8)

** Configurable via software, GND-active/ +24V-active (applies to all inputs K1 ... K8)



***** IMPORTANT!** If there is no connection between Earth and GND on the elevator control-system side, it is essential that X1.2 be connected to earth!

2.4 Dimensions

2.4.1 Electronic card iCon – basic board

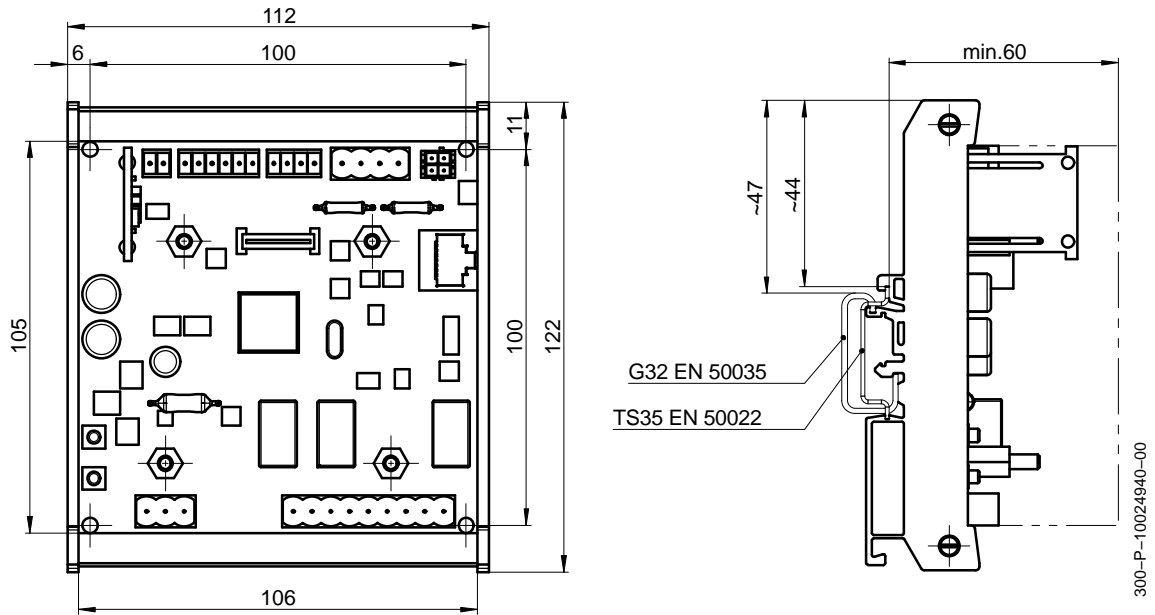

2.4.2 Electronic card iCon – with options board (2 additional switching outputs)

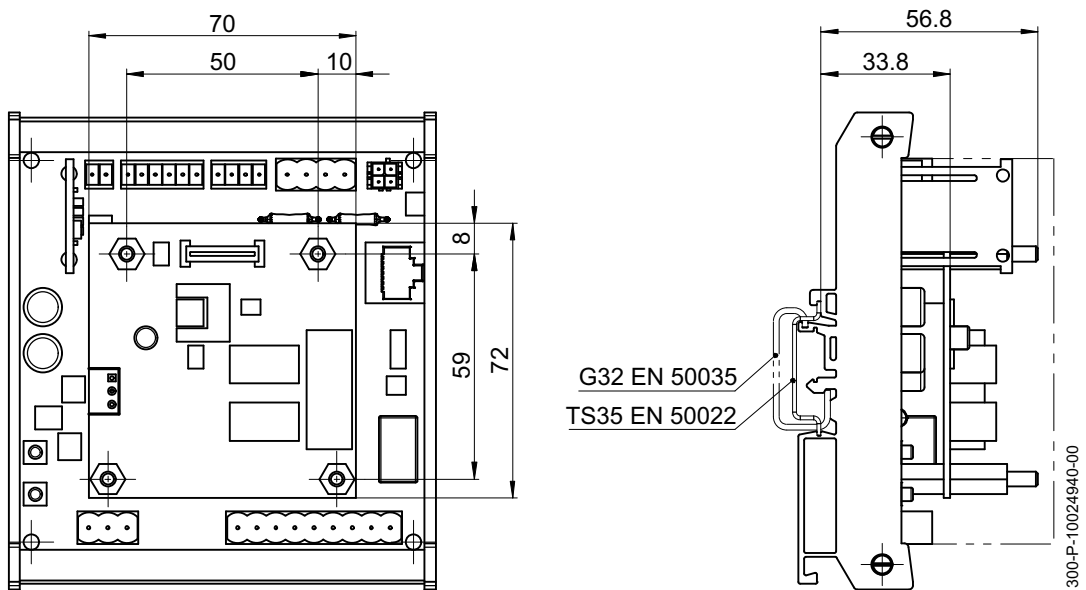

2.5 Pin assignments

iCon electronic card – basic board

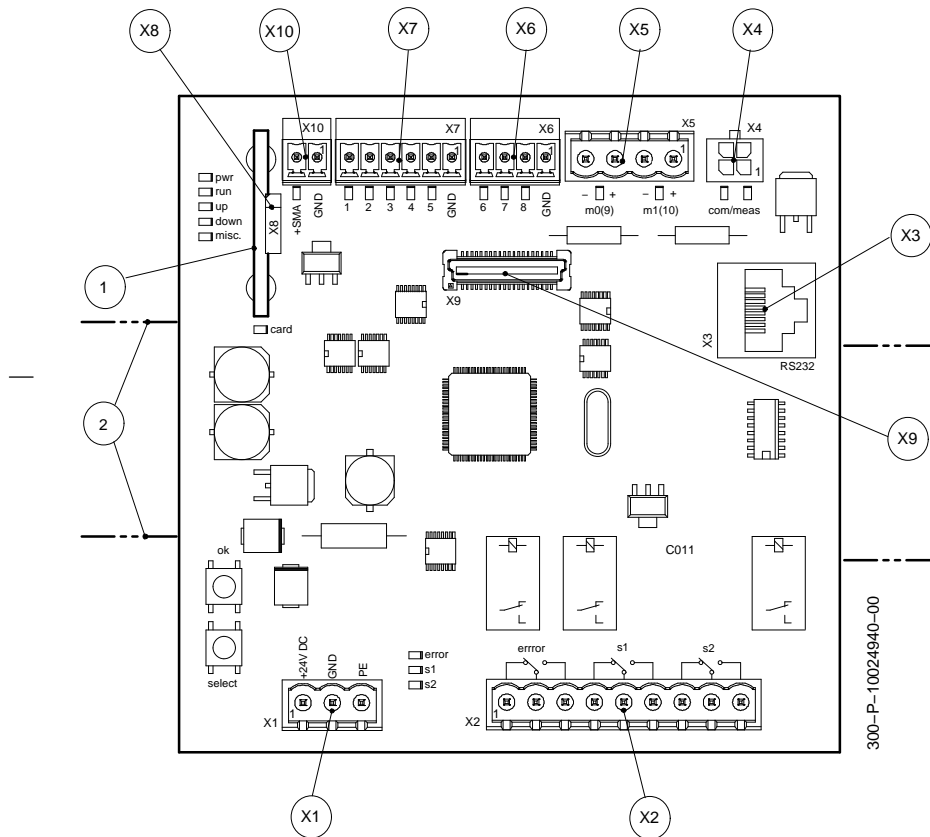

Item	Description
1	ParamCard
2	Top-hat rail TS15, TS35 (EN 50022) or G-type rail G32 (EN 50035)
X1	Connector block power supply
X2	Connector block switching outputs
X3	Connection Handterminal / PC
X4	Connection iBox

Item	Description
X5	Connector block solenoids
X6	Connector block command signals K6...K8
X7	Connector block command signals K1...K5
X8	Socket for ParamCard
X9	Socket for options boards
X10	Connector block, SMA



IMPORTANT!:

Two independent switching outputs are available on the iCon. For each switching output, a relay (s1 and s2) is available, each with a break/make contact.



IMPORTANT!:

K coding and binary coding are possible. For other information, please contact BUCHER!

2.5.1 Options board, switching output

Options board for version with pressure switch

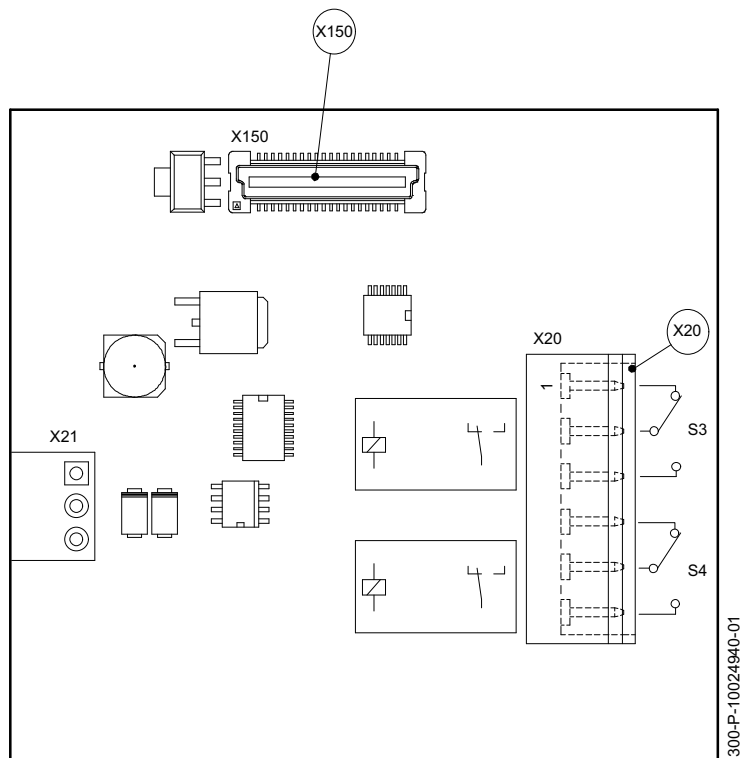

Item	Description
X-20	Connector block, switching outputs
X-21	Not used

Item	Description
X-150	Socket for options board

2.6 Dummy iCon – optional

2.6.1 Description

The "Dummy iCon" can be pre-installed in the control cabinet as a "placeholder" instead of the real iCon (control electronics for the iValve). It has all the plug connectors that the iCon has, so that the wiring can also be done in advance (cable lengths and cable positions).

2.6.2 How customers contact the test system

The central "X11" plug offers an additional benefit. All signals that are wired from outside to the iCon are available on this plug. Consequently, the wiring can be checked with an automatic test system.



2.7 Accessories

Part No.	Description
3007019906	Dummy iCon
3007010231+	Handterminal including connecting cable
3007020027+	PC software "iWin", including connecting cable
3007020442+	Power supply module i250
3007022344+	Power supply module i500
3007020030+	Plug connector kit
3007010472+ 3000008998+ 3000009002+	Solenoid connection cable: 1.5 metre 6.0 metre 12 metre (for Halogen-free versions, contact Bucher)
3007019644+ 3007020460+ 3007020461+	iBox connection cable: 1.5 metre 6.0 metre 12 metre

3 Related documents

Reference	Description
300-D-9010542	Planning information iValve
300-I-9010544	Commissioning and maintenance iValve
300-I-9010543	Parametrization and maintenance iValve
300-S-9010437	Spare parts iValve / iCon – i250
300-S-9010548	Spare parts iValve / iCon – i500

info.ch@bucherhydraulics.com

www.bucherhydraulics.com

© 2017 by Bucher Hydraulics AG, CH-6345 Neuheim

All rights reserved.

Data is provided for the purpose of product description only, and must not be construed as warranted characteristics in the legal sense. The information does not relieve users from the duty of conducting their own evaluations and tests. Because the products are subject to continual improvement, we reserve the right to amend the product specifications contained in this catalogue.

Classification: 430.330.500..