

Safety for Hydraulics

Double pressure-relief cartridge valve, two-stage, series DDP



DDP 16



DDP 32

1 General description

- two-stage seat valve
- double service-line relief valve in one cartridge
- protects the pump and/or the actuator and the system against over-pressure

2 Advantages

- for protecting two service lines against over-pressure
- is therefore able to replace two conventional pressure-relief valves
- available either with a common pressure setting for the A and B lines, or with independently-adjustable settings for A and B
- good flow characteristics
- suitable bodies with threaded or manifold ports are available - please consult Bucher Hydraulics

3 Application

- for primary pressure-relief in closed circuits, or secondary relief where the two service lines are to be protected at the same pressure, or at different pressures
- for installation in manifold blocks

4 Symbols

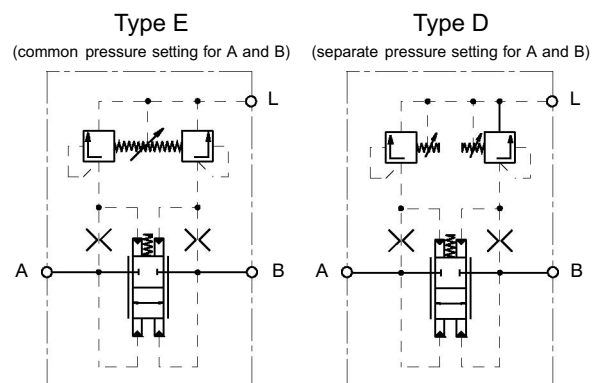

5 Main characteristics



Important: for applications outside these parameters, consult Bucher Hydraulics

General characteristics	Description, value, unit
Type	two-stage seat valve
Mounting method	screw-in cartridge
Ports DDP 16 DDP 32	A, B = \varnothing 16 mm, L = \varnothing 3 mm A, B = \varnothing 32 mm, L = \varnothing 4 mm
Mounting attitude	unrestricted
Flow direction	A → B, B → A
Weight DDP 16 DDP 32	E = 0.6 kg, D = 0.8 kg 1.6 kg

Hydraulic characteristics	Description, value, unit
Size	16/32
Nominal flow rate DDP 16 DDP 32	400 l/min 700 l/min
Min. pressure setting	flow-dependent; ⇒ performance graphs, section 10
Max. pressure setting	480 bar
Resistance to flow (Δp -Q)	⇒ performance graphs, section 10
Max. working pressure	480 bar
Hydraulic fluid	Mineral oil to DIN 51524 and DIN 51525 (HL/HLP). Other fluids - consult Bucher Hydraulics
Operating temperature range	-20 °C ... +80 °C, for other temperatures consult Bucher Hydraulics
Temperature rating - seal materials Nitrile (standard) Nitrile (low temperature) Viton	-20 °C...+80 °C -50 °C...+80 °C -20 °C...+200 °C
Viscosity range min. viscosity max. viscosity	10 - 380 mm ² /s (cSt) recommended 2.8 mm ² /s (cSt) 1500 mm ² /s (cSt)
Filtration/cleanliness class	NAS 1638 class 9, β 10 ≥ 75 ISO 4406 class 18/15

6 Safety information

- this valve must only be used for the purpose for which it has been designed
- it must only be adjusted by qualified personnel
- before removing or disassembling the valve, all hydraulic pressure must be vented from the system - double check!
- the valve must not be opened without the express permission of the manufacturer

7 Installation information

- observe all port designations (⇒ section 11)
- protect seals from damage
- observe the tightening torques (⇒ section 11)

8 Pressure-adjustment information

Pressure increase → clockwise ↻
Pressure reduction → counter-clockwise ↻

Rate of pressure change

NG 16 → D = 250 bar/full rotation
→ E = 350 bar/full rotation
NG 32 → D = 230 bar/full rotation
→ E = 350 bar/full rotation

After making an adjustment, always secure the adjusting screw with the lock nut to prevent drift
(tightening torques D = 8 Nm / E = 50 Nm; ⇒ section 11)

9 Functional description, sectional view

9.1 Type E, with common pressure setting for A and B

9.1.1 Neutral position (the load pressures at A and B are below the pressure setting)

Pilot poppets (3) and (4) are held in their closed position by the compression spring (5). Spool (2) remains in the closed position.

9.1.2 Relieving pressure (at the pressure setting)

When the pressure at A or B falls back below the valve setting, the corresponding pilot poppet closes and spool (2) is returned to its closed position by the hydraulic forces and the compression spring (1). The connection from A to B or B to A is again closed.

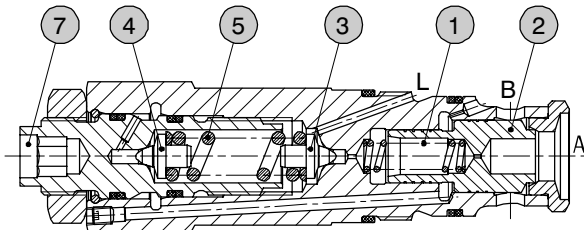

9.1.3 Valve closure

When the pressure at A or B falls back below the valve setting, the corresponding pilot poppet closes and spool (2) is returned to its closed position by the hydraulic forces and the compression spring (1). The connection from A to B or B to A is again closed.

1	Spring
2	Spool
3	Pilot poppet
4	Pilot poppet
5	Spring
7	Adjusting screw

9.2 Type D, with independent pressure settings for A and B

The operation is similar to that of the type E valve, except that pilot poppets (3) and (4) can be independently set to different pressure levels by means of the separate compression springs (5) and (6).

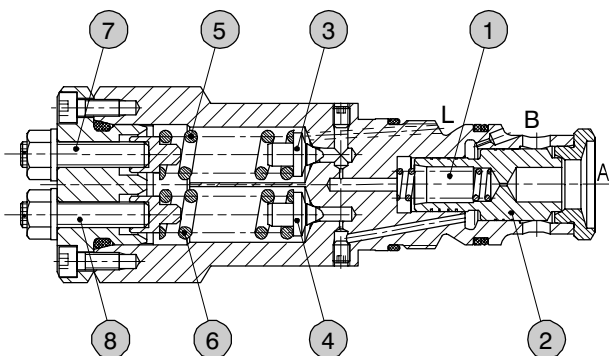

1	Spring
2	Spool
3	Pilot poppet
4	Pilot poppet
5	Spring
6	Spring
7	Adjusting screw
8	Adjusting screw

10 Performance graphs

measured at 33 mm²/s (cSt)

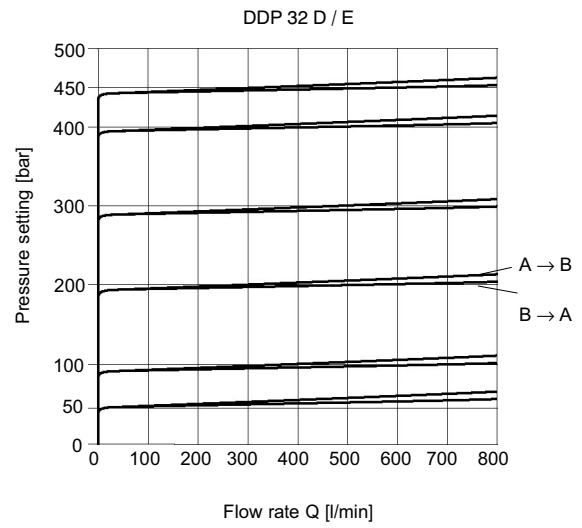
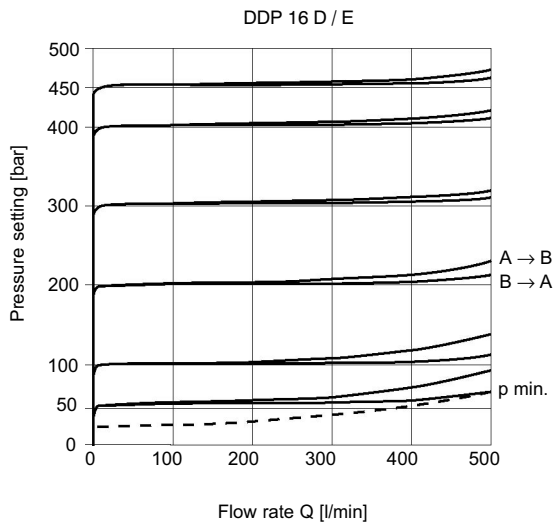

11 Dimensions, mounting cavity

11.1 DDP 16 E / D

Type E

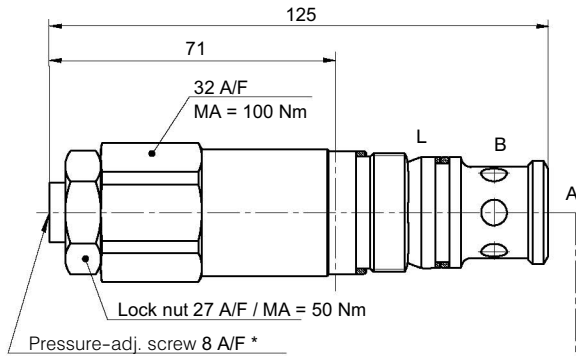

Type D

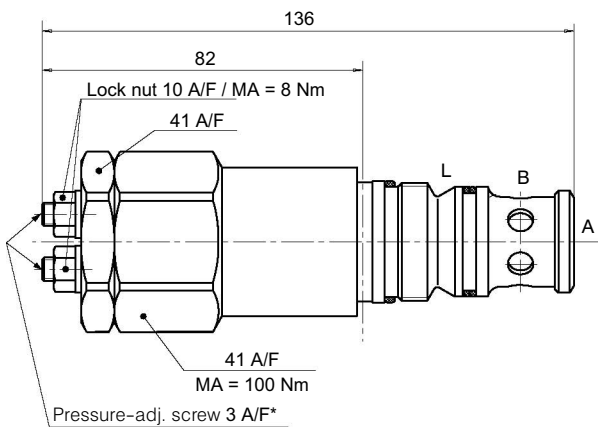

Mounting cavity

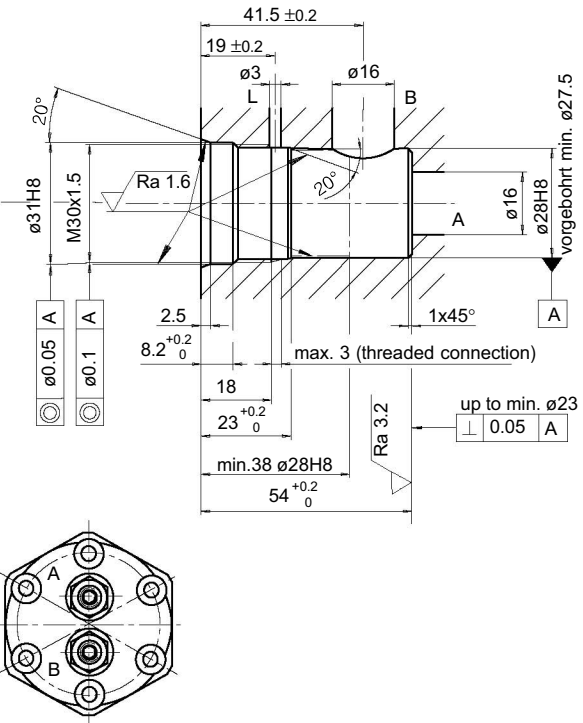

* for pressure-adjustment information, see Sec 8

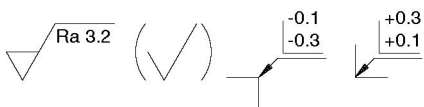

Note: Bores B and L can be positioned anywhere around circumference.

11.2 DDP 32 E / D

Type E

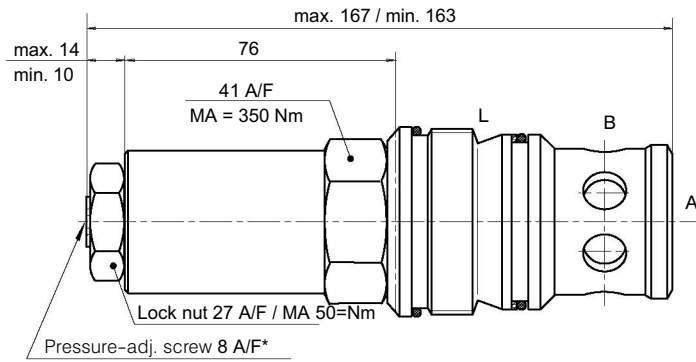

Type D

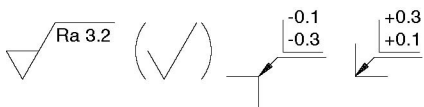
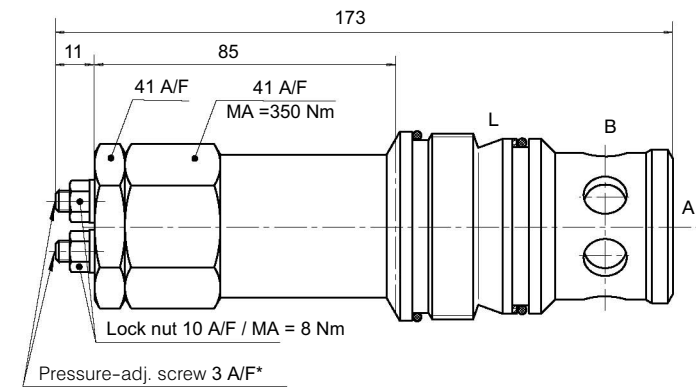

Mounting cavity

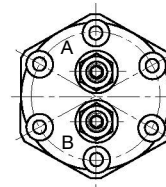
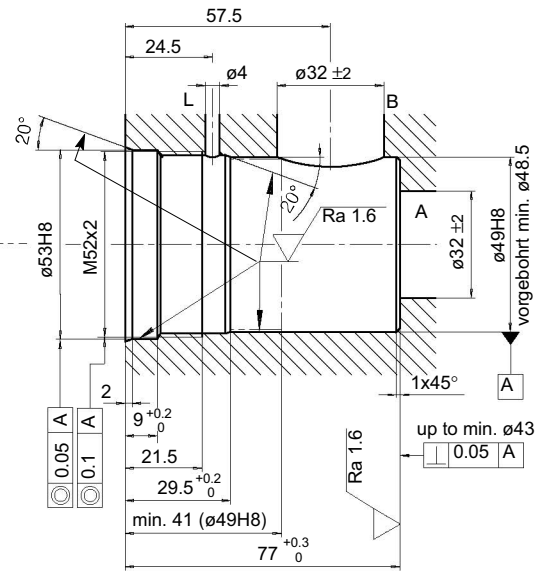

* for pressure-adjustment information, see Sec. 8

 Note: Bores B and L can be positioned anywhere around circumference.

12 Model code key

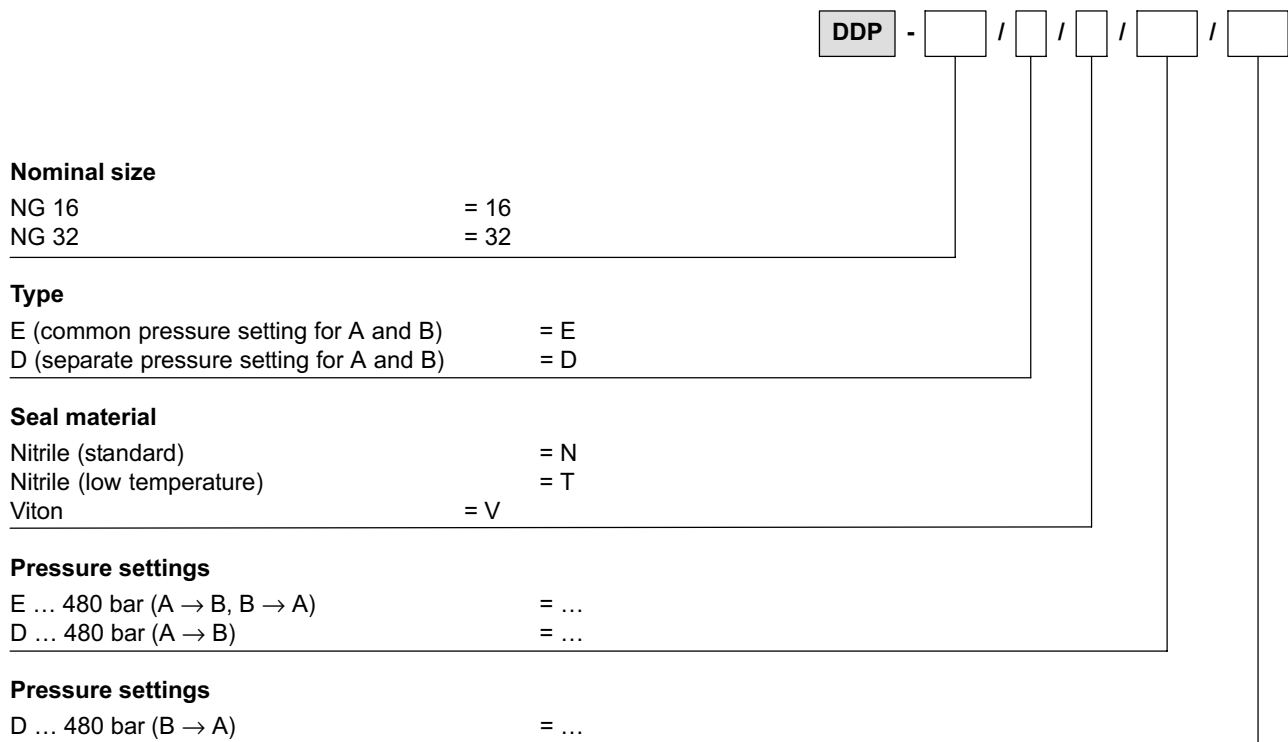

info.nh@bucherhydraulics.com

www.bucherhydraulics.com

© 2006 by Bucher Hydraulics AG, CH-6345 Neuheim.

All rights reserved.

Data is provided for the purpose of product description only, and must not be considered as warranted characteristics in the legal sense. The information does not relieve users from the duty of conducting their own evaluations and tests. Because the products are subject to continual improvement, we reserve the right to amend the product specifications contained in this catalogue.