

Cartridge Check Valve, Size 16

$Q_{\max} = 160 \text{ l/min (42 gpm)}$, $p_{\max} = 500 \text{ bar (7100 psi)}$

Cone seat design

Series RVP 16...



- Compact design for cavity type according to Bucher standard – M30x1.5
- Deployable in high pressure applications
- Virtually leak-free in no-flow direction
- Hardened, polished seat section and cone
- Option of different opening pressures
- High flow rates with low Δp
- Browned

1 Description

Series RVP... check valves are size 16, high performance screw-in cartridges with an M30x1.5 mounting thread. The poppet/seat design ensures that the cartridges are leak-tight from B → A. 4 variants with a fixed opening pressure are available.

These screw-in cartridges are predominantly used in mobile and industrial applications where leak-free shut-off in one direction is important. The cartridges can be screwed into the cavity type according to Bucher standard – M30x1.5.

2 Symbol



3 Technical data

| General characteristics | Description, value, unit | |
|---------------------------|------------------------------|----------------------|
| Designation | cartridge check valve | |
| Design | cone seat design | |
| Mounting method | screw-in cartridge – M30x1.5 | |
| Tightening torque | 70 Nm ± 10 % | (50 ± 10 % ft-lbs) |
| Size | size 16 | |
| Weight | 0.15 kg | (0.33 lbs) |
| Mounting attitude | unrestricted | |
| Ambient temperature range | -25 °C ... +80 °C | (-13 °F ... +176 °F) |
| Surface protection | browned | |

| Hydraulic characteristics | Description, value, unit | |
|----------------------------|--------------------------|------------|
| Maximum operating pressure | 500 bar | (7100 psi) |
| Maximum flow rate | 160 l/min | (42 gpm) |

| Hydraulic characteristics | Description, value, unit |
|---|--|
| Flow direction | A → B, check valve function B → A, blocked direction, seat-tight |
| Opening pressure | 0.3 / 1.0 / 15 / 20 bar (4.3 / 15 / 215 / 285 psi) |
| Hydraulic fluid | HL and HLP mineral oil to DIN 51 524; for other fluids, please contact BUCHER |
| Hydraulic fluid temperature range | -25 °C ... +80 °C (-13 °F ... +176 °F) |
| Viscosity range | 10...650 mm ² /s (cSt), recommended 15...250 mm ² /s (cSt) |
| Minimum fluid cleanliness Cleanliness class to ISO 4406 : 1999 | class 20/18/15 |

4 Performance graphs

measured with oil viscosity 33 mm²/s (cSt)

$\Delta p = f(Q)$ Pressure drop - Flow rate characteristic

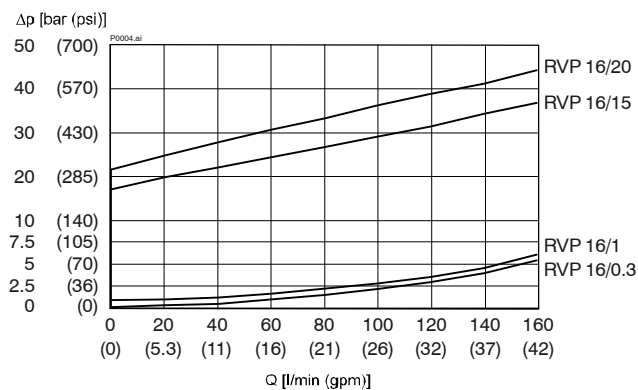

5 Dimensions & sectional view

Example for the dimensional units:

0.79 = 0.79 mm [millimeter]

(.031) = 0.031" [inch]

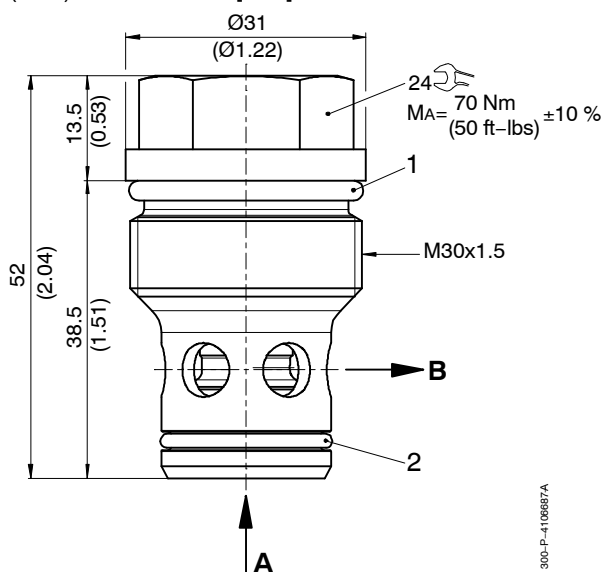

6 Installation information



IMPORTANT!

When fitting the cartridges, use the specified tightening torque. No adjustments are necessary, since the cartridges are set in the factory.



ATTENTION!

Only qualified personnel with mechanical skills may carry out any maintenance work. Generally, the only work that should ever be undertaken is to check, and possibly replace, the seals. When changing seals, oil or grease the new seals thoroughly before fitting them.

| Item | Qty. | Description |
|------|------|--|
| 1 | 1 | O-Ring $\varnothing 25.07 \times 2.62$ |
| 2 | 1 | O-Ring $\varnothing 18.77 \times 1.78$ |



IMPORTANT!

Item No. 3000302374 = seal kit NBR (nitrile)
Item No. 3000302375 = seal kit FKM (viton)
Item No. 3000302376 = seal kit MIL (low temp.)

7 Ordering code

Ex. RVP 16 / 0.3 / N

| | | |
|-----|---|--|
| RVP | = | cartridge check valve |
| 16 | = | size 16 |
| 0.3 | = | opening pressure 0.3 bar / 4.3 psi |
| 1 | = | opening pressure 1.0 bar / 15 psi |
| 15 | = | opening pressure 15 bar / 215 psi |
| 20 | = | opening pressure 20 bar / 285 psi |
| N | = | NBR (Nitrile) seals (standard) |
| V | = | FKM (Viton) seals |
| T | = | MIL (low temperature) seals (special seals - please contact BUCHER) |

8 Cartridge cavity

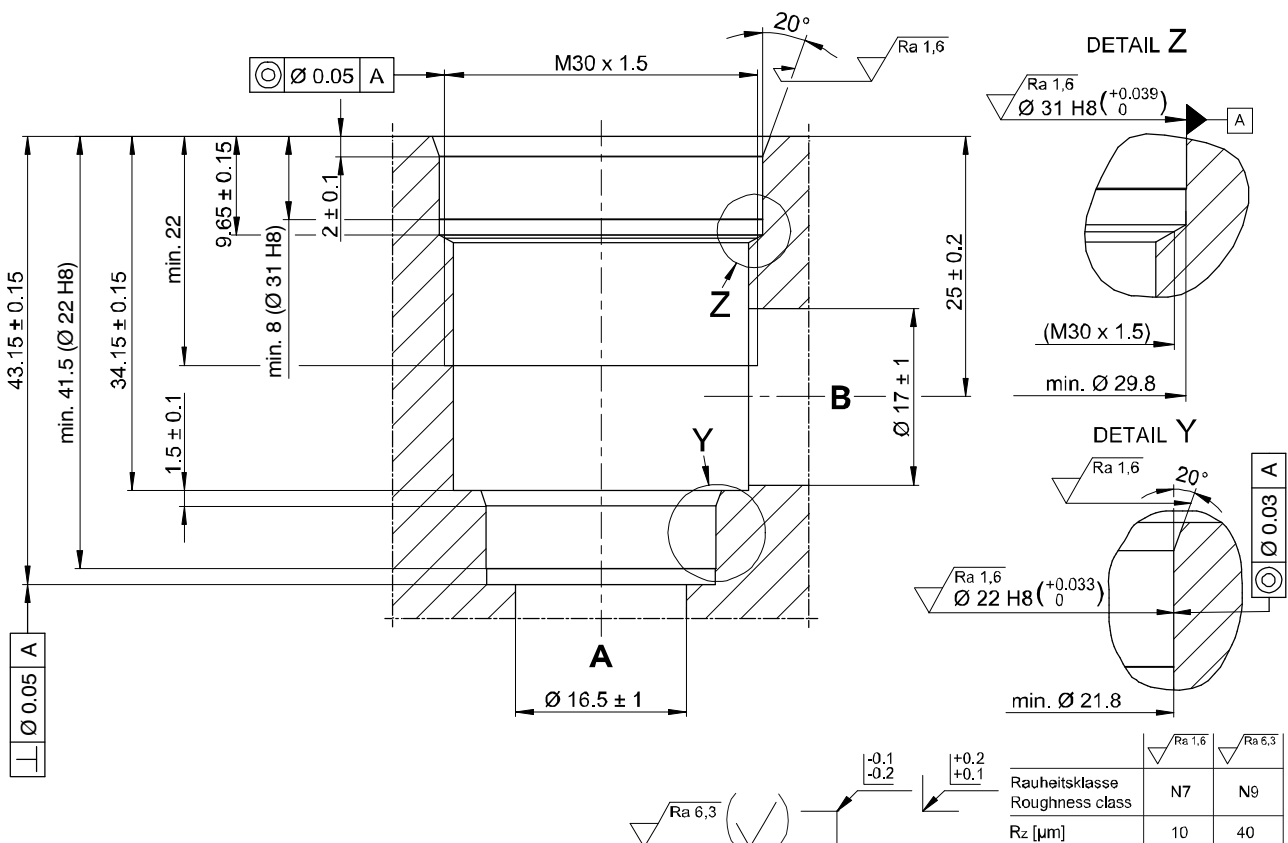

ATTENTION!

You must maintain the specified positional and diametral tolerances. To ensure trouble-free operation of the screw-in cartridges, we strongly recommend that pilot drilling, boring, reaming and cavity thread-cutting are always performed in one setup.

info.ch@bucherhydraulics.com

www.bucherhydraulics.com

© 2018 by Bucher Hydraulics AG, CH-6345 Neuheim

All rights reserved.

Data is provided for the purpose of product description only, and must not be construed as warranted characteristics in the legal sense. The information does not relieve users from the duty of conducting their own evaluations and tests. Because the products are subject to continual improvement, we reserve the right to amend the product specifications contained in this catalogue.

Classification: 430.315.340.305.330